

REVISIONS					
REV.	DESCRIPTION	DRAWN	DATE	CHECK	APPROVAL

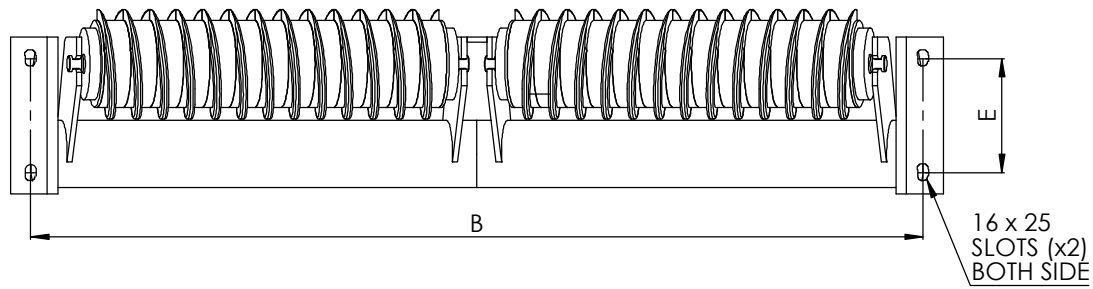

DIRECTION OF SPIRAL

DIRECTION OF SPIRAL

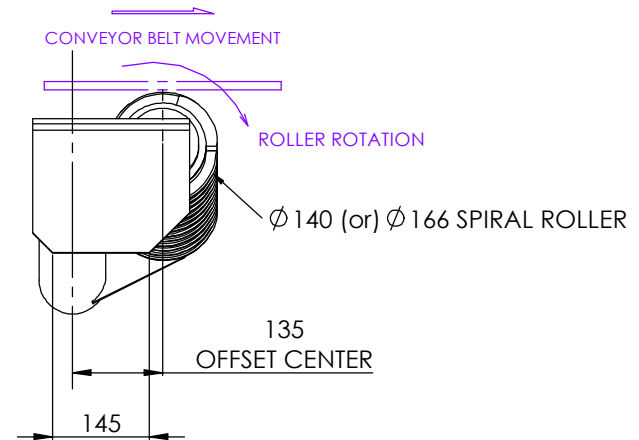
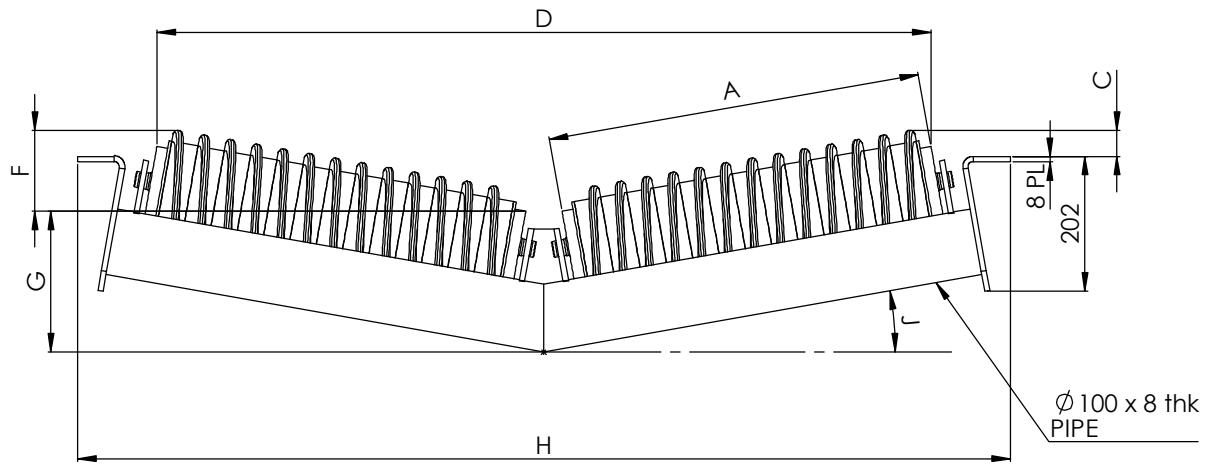

	DIM "A"	DIM "B"	DIM "C"	DIM "D"	DIM "E"	DIM "F"	DIM "G"	DIM "H"	ANGLE "J"	ROLLER $\phi$ "K"	SHAFT UNDERCUT $\phi$ "L"	SHAFT $\phi$ "M" BETWEEN BRG	BACK/BACK "N"	OVERALL LENGTH "P"	SLOT DETAILS "R"	BEARING SPEC.
CUSTOMER TO FILL					-N.A-			-N.A-				-N.A-				
**	**	**	**	**	**	**	**	**	**	**	**	**	**	**	**	**
KINDER USE ONLY	-N.A-	-N.A-		-N.A-		-N.A-	-N.A-		-N.A-							

ALL DIMENSIONS ARE IN MM

NOTE:

1. REMOVE ALL BURRS AND SHARP EDGES.
2. FRAME FINISH: TO BE ADVISED (PAINT / HOT DIP GALVANIZE).

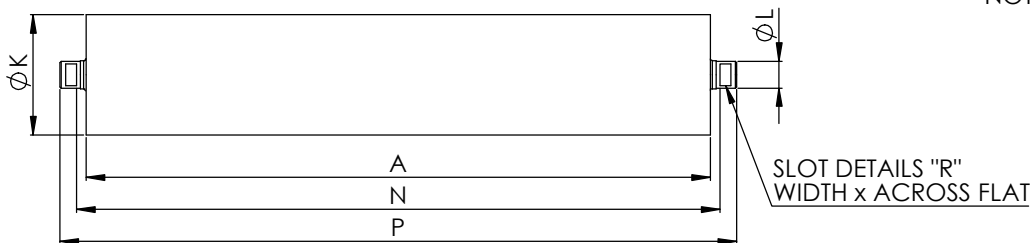

2	$\phi 140 / \phi 166$ SPIRAL ROLLER	2		
1	OFFSET VEE RETURN SPIRAL IDLER FRAME	1		
Item No.	Description	Qty.	Weight	Ref.

DIMENSIONS IN MILLIMETERS

DO NOT SCALE

3RD ANGLE PROJECTION

SCALE	1:4	DATE	09.0714
DRAWN	V.R	CHECKED	-
APPROVED	-		

TITLE  
WORKSHEET - OFFSET SPIRAL VEE RETURN IDLER;  
 $\phi 140 / \phi 166$  ROLLER;

ORDER NO.	
CUSTOMER	
REF DWGS	XXXX
DRAWING NO.	K3415
REV.	-

MATERIAL STATUS

DIM IN WHOLE No.	1 DEC	2 DEC	ANGLE
TOLS	$\pm 1.0$	$\pm 0.5$	$\pm 0.25$
MATERIAL			$\pm 0.5^*$

A1  
THIS DRAWING IS THE PROPERTY OF KINDER & CO AND MUST BE RETURNED UPON REQUEST. IT MAY NOT BE COPIED OR USED WITHOUT THE WRITTEN PERMISSION OF KINDER & CO ABN 280 064 892 38

**KINDER**  
EXPERIENCE INNOVATION PRODUCTIVITY  
EMAIL: sales@kinder.com.au www.kinder.com.au

# K-Vee Return Spiromax® Cleaning Idler Worksheet

Name: \_\_\_\_\_

Company: \_\_\_\_\_

Site/Operation Location: \_\_\_\_\_

Contact Number: \_\_\_\_\_

Email: \_\_\_\_\_

Date: \_\_\_\_\_

Entered or Approved  
by Kinder Employee: \_\_\_\_\_

Kinder Document ID: \_\_\_\_\_

Kinder Reference Drawing: K3415

**Issue Date: 11/07/2014**

**Kinder Australia Pty Ltd**

Subject to © Kinder Australia Pty Ltd  
ABN: 28 006 489 238

26 Canterbury Rd, Braeside VIC 3195  
PO Box 1026, Braeside VIC 3195  
☎ +61 3 8587 9111  
📠 +61 3 8587 9101

**kinder.com.au**

📧 conveyorsolutions@kinder.com.au

