

Installation Instructions: K-Magnetic Speed Switch

Kinder Australia Product:	K-Magnetic Speed Switch
Product Category:	Conveyor Pulleys & Lagging
Issue Date:	18.06.2013
Revision:	1

Overview:

The K-Magnetic Speed Switch is a pre-set inductive proximity switch, and it is intended to be used with a PLC or similar device that can monitor the number of pulses per revolution and select a desired output.

Caution: As with any electrical equipment, the K-Magnetic Speed Switch should be installed by trained personnel using appropriate practices per the National Electric Code, including electrical disconnect and lockout practices, reference ANSI Z244.1.



Procedure:

READ THESE INSTRUCTIONS CAREFULLY BEFORE STARTING INSTALLATION.

SECTION 1 - GENERAL

The K-Magnetic Speed Switch is a pre-set inductive proximity switch. As the magnetic coupler rotates, it opens and closes an electrical circuit a pre-set number of times per revolution. The K-Magnetic Speed Switch is intended to be used with a PLC or similar device that can monitor the number of pulses per revolution and select a desired output.

The exceptions are the MS1-SS, MS1S-SS, and MS1SLP-SS which have a built-in 4 second delay and can be connected to a relay. This device is not intended for use in hazardous areas as defined by the NEC, articles 500-504. Intrinsically safe magnetic speed switches are not presently available.

Installation Instructions: K-Magnetic Speed Switch

SECTION 2 - SELECTION

The K-Magnetic Speed Switch is available in either 1, 2, 4, or 12 pulses per revolution. For most applications, a 1-pulse sensor will be suitable. Higher numbers of pulses result in higher resolution and quicker response, especially at lower speeds. The 12 pulse switch is only available as a 3-wire DC and must be specified for NPN or PNP operation. (See the provided wiring diagrams in section 5) The standard magnetic coupler is 2" in diameter and is acceptable for most applications. A 1" coupler is available for shaft diameters under 2". (See Figure 1)

Figure 1



Figure 2



The standard K-Magnetic Speed Switch requires 3" clearances beyond the end of the shaft. For those applications with low clearance, a low profile switch is available that requires 1-7/8" of clearance. (See Figure 2)

Installation Instructions: K-Magnetic Speed Switch

A stop switch option is available on many of the configurations. The stop switch is a normally open switch that has a built-in timer. The timer has a 2 second start-up delay and 4 second shut- down delay. Two seconds after the sensor detects the first pulse, the switch closes.

The switch remains closed as long as another pulse is detected within 4 seconds. Once 4 seconds pass with no pulse detected, the switch opens. These models are suitable to connect directly to a relay with no PLC necessary. The stop switch option is only available in AC. For part numbering reference guide please refer to Figure 3.

Figure 3

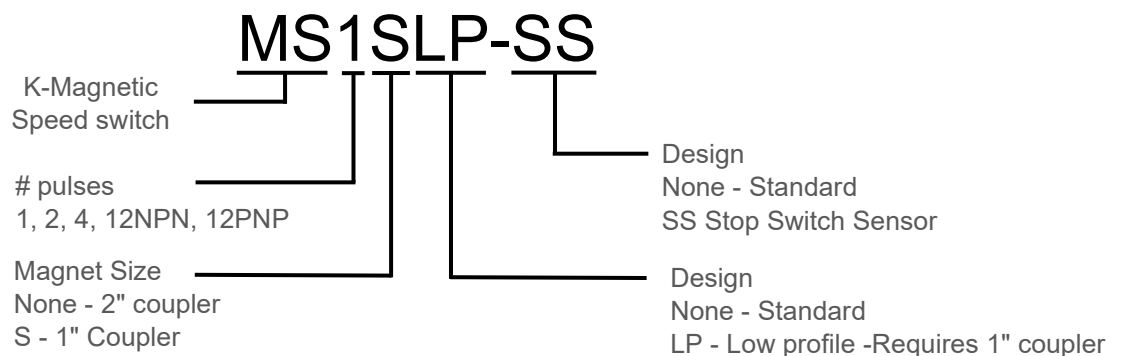

SECTION 3 - MOUNTING INSTRUCTIONS

1. Isolate, lock and danger tag the conveyor at the main positive isolator in accordance with the appropriate health and safety regulations in forces at your works to prevent unauthorised starting.
2. The K-Magnetic Speed Switch is to be installed on the end of a rotating shaft.
3. Attach the K-Magnetic Speed Switch to the end of the shaft as close to the centre of the shaft as possible. Exact centring is not necessary, but offset mounting will result in wobbling of the K-Magnetic Speed Switch. Excessive wobbling, especially at high speeds, may cause the K-Magnetic Speed Switch to be thrown from the shaft.
4. Fasten cable guard (flexible conduit) into place with zip-tie or some type of strap to help keep the unit in place.
5. The installation is now complete, remove all tools and equipment, and replace guards.
6. Remove personnel danger tags. Unlock main positive isolator and close, start belt on test or manual control. Return conveyor to service and observe performance.

Installation Instructions: K-Magnetic Speed Switch

SECTION 4 - WIRING INSTRUCTIONS

1. Read and understand all wiring, selection, and mounting instructions prior to installation. If necessary, contact a PPI Applications Engineer.
2. Disconnect and lockout power before starting wiring procedure. Do not apply a voltage across the wires until a load such as a relay circuit has been installed. The sensor may be permanently damaged if prematurely powered.
3. To maintain reliability, use proper external wire protection. All K-Magnetic Speed Switch conduit ends have ½" NPT male threads and nut for conduit connection. Conduit protection of entire wiring circuit is recommended.
4. The inductive proximity sensor installed in the K-Magnetic Speed Switch is factory set. There is no setup required and no maintenance is required in the future. Wiring diagrams follow.

CAUTION:

Do Not...

Use an incandescent light bulb as a load. The extremely high cold current will cause an overload condition.

Do Not...

Operate without a load. A dead short will result that may cause irreparable damage.

Do Not...

Directly operate a motor with the sensor. Always use a motor starter, relay, or other appropriate device.



Installation Instructions: K-Magnetic Speed Switch

SECTION 5 - SENSOR INFORMATION & SCHEMATICS

	MS1, MS2, MS4, MS1S, MS2S, MS4S, MS1SLP, MS2SLP, MS4SLP	MS1-SS, MS1S-SS, MS1SLP-SS	MS12PNP, MS12NPN	
Type	2 wire AC/DC inductive proximity sensor normally open with resettable short circuit protection	2 wire AC inductive proximity sensor normally open with standard 4 second hold	3 wire DC inductive proximity sensor normally open with resettable short circuit protection	
Operating Voltage	AC 40 – 250V AC	DC 20 – 250V DC NPN or PNP	AC 20 – 132V AC	DC 10 – 30V DC (NPN or PNP, Depending on model)
Maximum Current	250 mA @ 70°F 200 mA @ 160°F	250 mA @ 70°F 200 mA @ 160°F	5-300 mA	200 mA
Off State Leakage	<=1.7 mA @ 120V AC	<=2.0 mA	<=1.7 mA	<=120.0 μA
Voltage Drop	<=4V @ >25 mA	12V @ <10 mA	<5V AC	<=1.2 V

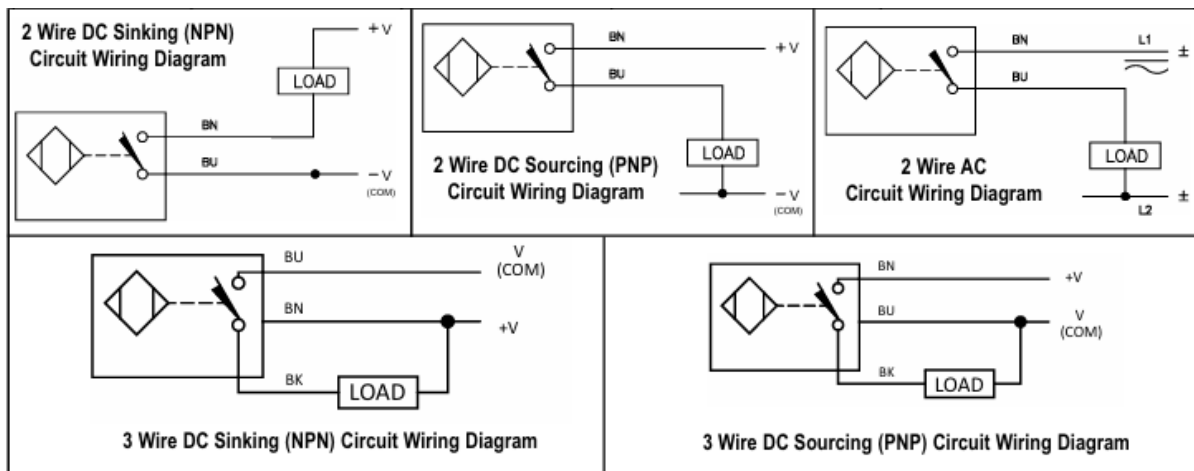

Installation Instructions: K-Magnetic Speed Switch

SECTION 6 – PRODUCT PART LIST

	Part Number	Product Description
Standard Product	MS1	1 Pulse per revolution, Standard housing, 2" magnet base
	MS2	2 Pulse per revolution, Standard housing, 2" magnet base
	MS4	4 Pulse per revolution, Standard housing, 2" magnet base
	MS12PNP	12 Pulse per revolution, Standard housing, 2" magnet base
	MS12NPN	12 Pulse per revolution, Standard housing, 2" magnet base
1" Magnet Base	MS1S	1 Pulse per revolution, Standard housing, 1" magnet base
	MS2S	2 Pulse per revolution, Standard housing, 1" magnet base
	MS4S	4 Pulse per revolution, Standard housing, 1" magnet base
	MS12SPNP	12 Pulse per revolution, Standard housing, 1" magnet base
	MS12SNPN	12 Pulse per revolution, Standard housing, 1" magnet base
Low Profile Housing	MS1SLP	1 Pulse per revolution, Low profile housing, 1" magnet base
	MS2SLP	2 Pulse per revolution, Low profile housing, 1" magnet base
	MS4SLP	4 Pulse per revolution, Low profile housing, 1" magnet base
Stop Switch Design	M-SS	Constant signal voltage, Standard housing, 2" magnet base
	MS-SS	Constant signal voltage, Standard housing, 1" magnet base
	MLP-SS	Constant signal voltage, Low profile housing, 1" magnet base