

# Installation Instructions: K-Superline® Polyurethane Lining System

<b>Kinder Australia Product:</b>	K-Superline® Polyurethane Lining System
<b>Product Category:</b>	Flow & Anti-Wear Liners
<b>Issue Date:</b>	17/02/2022
<b>Revision:</b>	0

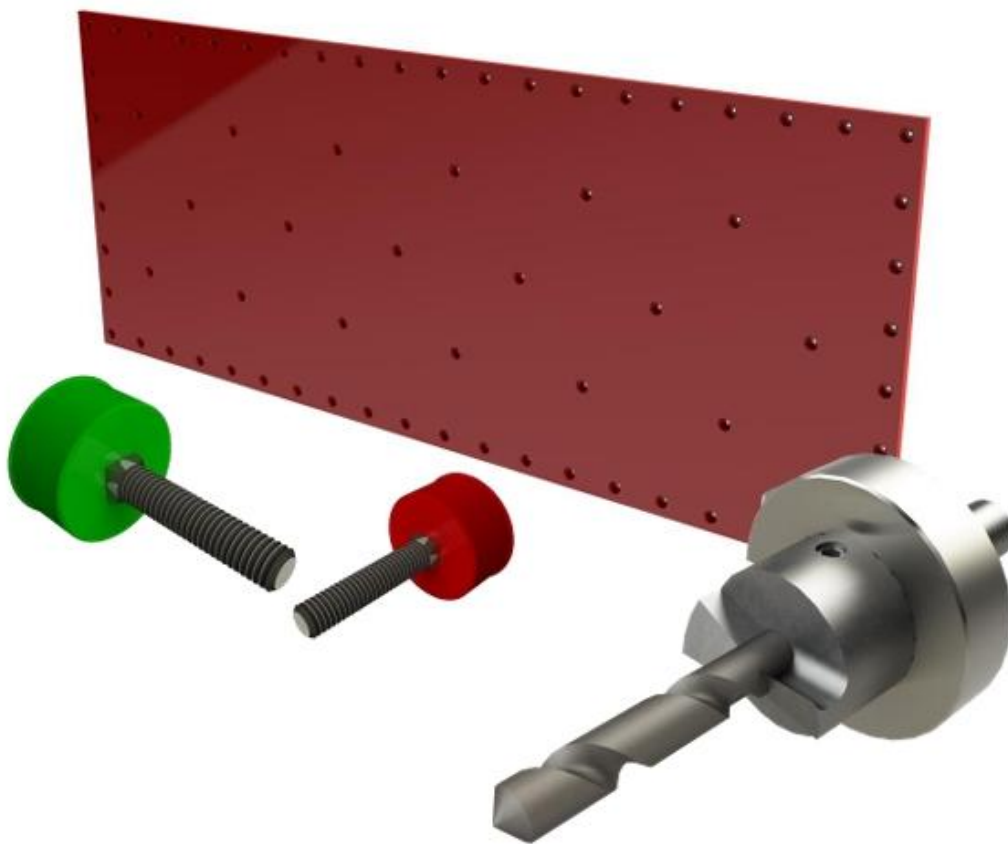

**⚠ WARNING ⚠**

**Always obey all applicable safety rules.  
Be sure all power to the conveyor has been disconnected and controls are locked out.**

# Installation Instructions: K-Superline® Polyurethane Lining System

## Installing the K-Superline® Polyurethane Lining

Correct liner installation is essential to preventing build-up of material and accelerated wear of the liner. To ensure that you get the best performance out of your liner make sure to follow all instructions suited to your application and to acknowledge all notes and warnings.

### Cutting

Kinder offers professional CNC and waterjet cutting services to ensure that K-Superline® liner sheets are cleanly cut to shape, including fastener holes, with a high level of precision and accuracy. If your liner is metal or fabric backed it is recommended to use CNC or waterjet cutting over manual tool handling.

Use measuring equipment and engineering drawings to determine the size and shape required to fit the liner into the application. Either provide these details to Kinder or mark the liner to designate the cutting lines. Make sure to cut the shape using an open tooth band saw or heavy-duty reciprocating saw. Use a coarse tooth blade when cutting polyurethane only, and switch to a fine-tooth blade if a steel weld plate is encountered. When cutting, advance the blade slowly and run at low RPM to minimize friction and heat build-up. Spray water or other liners. Use cutting lubricant on the area to make sawing easier. Do not use a circular saw to cut these pieces.

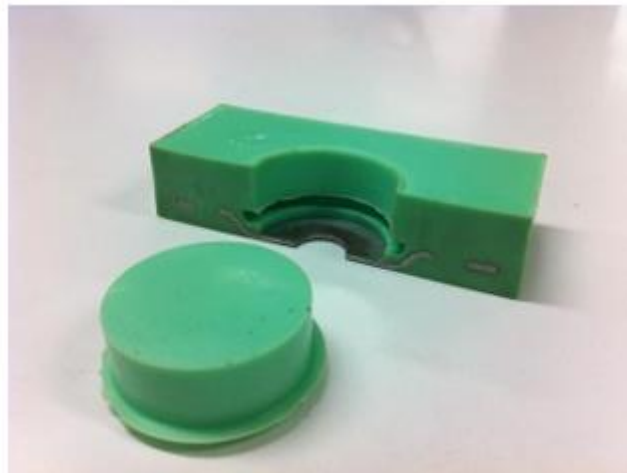

Metal backed Superline® and plug for weld in

### **WARNING**

**Burning elastomers give off toxic fumes. Take extra time to minimize heat exposure. Have a fire extinguisher and a bucket of water with rags available. If flames or smolders do occur, extinguish immediately. Use of forced air ventilation or an in-line respirator is strongly recommended.**

If your installation will be using a fastening method that requires counterboring, and you have opted to complete this yourself, then you will need a counterboring tool to match your fastener. Counterbores for fabric or metal backed liner types can have counterbores closer to the backside of the sheet due to the reinforcing, in this case it may be possible to use a thinner liner. Drilling is best done using a high torque drill and low RPM should be used. Allow time between bore holes for the bit to cool if required. Spraying the hole with water will also improve boring. Be sure to clean away shavings before welding or gluing

# Installation Instructions: K-Superline® Polyurethane Lining System

## Bolting

Fasteners for the K-Superline® can be either coated head bolts or plug and bolt style. The heads of the coated cap bolts are made up of the same K-Superline® polyurethane material bonded directly onto the bolt, while the plugs, which are the same material, and are designed to be fixed into place with an adhesive

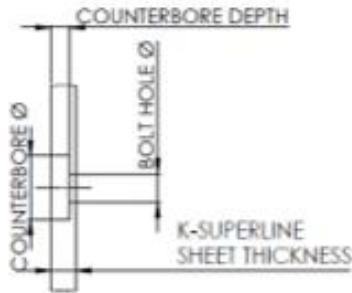

COUNTERBORE HOLE  
SCALE 1:1

The profile of a typical liner counterbore should be completed to match the given dimensions. Any overhangs or gaps can become starting points for material hang-up and caking. Kinder can provide counterbore tools for this process.

Optimal counterboring should result in the coated head of the bolt or adhered plug lying flush with the liner so that any potential hang-up points are eliminated. This can be tested before install as the counterbores are drilled. Ensure any burrs are removed prior to operation.

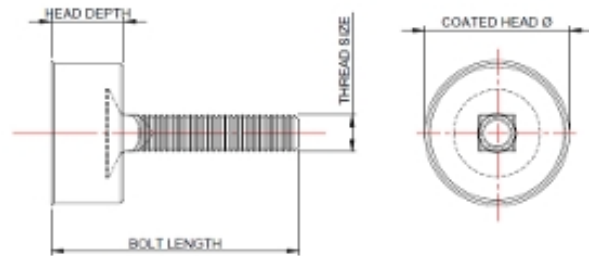

## Standard Bolt Sizing Chart

SUPERLINE® SHEET THICKNESS	THREAD SIZE (in)	COATED HEAD Ø (mm)	HEAD DEPTH (in)	BOLT LENGTH (mm)	MAX CHUTE THICKNESS (mm)	PART NUMBER
8	1/4"	28.6	1/4"	40	18	K-FAW-CB-1414-150
10					16	
13	3/8"	38.1	3/8"	43	12	K-FAW-CB-3838-150
				56	25	K-FAW-CB-3838-200
				68	38	K-FAW-CB-3838-250
19	3/8"	38.1	1/2"	46	9	K-FAW-CB-3812-150
				59	22	K-FAW-CB-3812-200
				72	34	K-FAW-CB-3812-250
25	3/4"	38.1	3/4"	52	9	K-FAW-CB-3834-150
				65	22	K-FAW-CB-3834-200
				78	34	K-FAW-CB-3834-250

1/2" and M12 bolt sizes available for sheets of thickness greater than 25. Consult Kinder for more information regarding bolts for your preferred liner and chute size

## Installation Instructions: K-Superline® Polyurethane Lining System

Using plugs to cover counterbored bolt holes is a simple method of preventing hang-up and caking around fasteners. Simply ensure that the bolt is properly secured and test that the plug fits snugly and is flush with the liner face. If the plug sits slightly proud of the liner face it is still acceptable as the plug can be buffed or grinded flush. It is recommended that a fast-setting polyurethane caulk is used to help keep the plug in place.

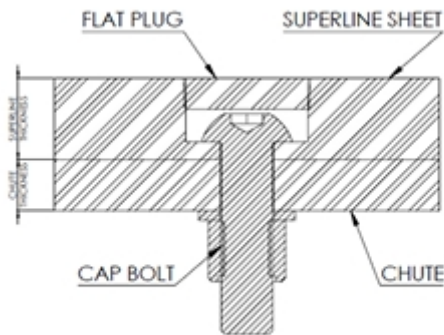

Flat and inset plug designs

If a plug becomes loose or pops out, it may allow material penetration or build-up through the weld hole. Try to remove the build-up and use an adhesive to seal the hole and secure the loose plugs as soon as possible. See pg. 5 for a list of acceptable sealants.

### Gluing

(Using K-REP-PRIMER and SC4000 - preferred only for fabric-backed K-Superline®)

1. Inspect the condition of the steel and rubber to ensure there are no defects.
2. The metal surface should be sandblasted to class 2.5. If this is not practical, the metal should be sanded back to white metal with a 16-grit sanding disc.
3. After sandblasting clean the metal surface with a white solvent, Toluene or Trichloroethane (number 10 cleaner). Use a clean rag.
4. K-REP-PRIMER should be applied on the metal surface immediately after sandblasting and cleaning is completed. The primer can be brushed or rolled on. Care should be taken not to create puddles or runs.
5. Allow to dry thoroughly for a minimum of 4 hours. Make sure to keep this new surface clean of any oil, grease or dust.
6. Apply one coat of K-REP-SC4000 cement to the metal surface at the rate of 1kg/m<sup>2</sup>. This should take approximately 1 hour to dry. Best results are achieved if this work is carried out in moderate weather conditions.
7. Clean the backing of the K-Superline® backing and have one coat of K-REP-SC4000 applied at the same time as the metal surface. It should also take approximately 1 hour to dry.

## Installation Instructions: K-Superline® Polyurethane Lining System

8. The second uniform coat of K-REP-SC4000 is then applied to both the K-Superline® and metal surface at the same time.

9. When these coats are touch dry, K-Superline® should be placed into position and pressed by rolling with a hand roller, or gently taped with a rubber mallet, to remove all air traps and to ensure all surfaces are bonded. Take care to make sure the edges are also bonded.

10. We strongly suggest installing cover strip edge protector to prevent the liner from being ripped away by the bulk material which migrated behind the back of liner.

### Welding

Position the liner as required. Apply pressure to the liner to ensure the weld disk is flush with the substrate. Drop a pipe segment (1.75" O.D. x 2" long) inside of the plug-hole opening. Hold in place with pliers or vice grips. Place welder inside of the pipe segment and plug weld around the disk hole. The pipe segment will act as a heat shield and will protect the liner from heat degradation and ignition. The pipe segments will build heat, so it is advisable to utilize multiple pipe segments. If flashes of hot slag hit the liner, use a wet rag to extinguish the smolder.

### Grinding/Buffering

If a plug sits proud of the liner face after installation it is best to grind off the excess material to prevent the location from promoting hang-up. Grinding should be completed with a low RPM grinder and buffing pad



**Ensure grinding is completed in a well-ventilated area. Burning elastomers give off toxic fumes. Take extra time to minimize heat exposure. Have a fire extinguisher and a bucket of water with rags available. If flames or smolders do occur, extinguish immediately. Use of forced air ventilation or an in-line respirator is strongly recommended.**

### Liner Wear Indicators

Liner wear indicators are dyed segments of the liner, 6mm thick, on the rear side of the liner. These indicators allow for wear hotspots and overall liner health to be quickly and easily evaluated, even in messy applications.

If your liner gets to the point that the wear indicator is visible it is usually best to consider replacing it as soon as possible. If the wear is not uniform across surface or is localised to a specific spot on the panel, depending on the geometry, it may be possible to rotate the panel or swap it with a similar shaped panel with less wear

# Installation Instructions: K-Superline® Polyurethane Lining System

## Recommended Adhesives

Typical Uncured Properties	Bostick 1100FS*	SikaFlex 11FC	SikaFlex 221	Loctite UR3370	Loctite 5510	3m 550FC
Skin over time (min)	70	-	45	25-30	-	-
Tack Free Time (min)	90	60-120	60	60-120	20-50	50-90
Curing time at 25° (days)	1.5-3	3-5	2-10	1-7	1-7	5mm per 24 hr
Typical Cured Properties						
Hardness (Shore A)	40-45	40-45	40	38	35-50	45
Modulus @ 100% Elongation (kPa)	450	-	-	-	-	1050
Tensile Strength (MPa)	1.65	1.55	1.8	2.4	1.5	3.1
Elongation At Break	850%	600%	500%	411%	320%	600%
Temperature Resistance	-40-82	-40-77	-40-90	-	-	-40-90

\*Bostick 1100FS is the recommended adhesive for this application.

## Sealing Gaps

After all liners are in place, caulk any remaining gaps with your selected adhesive. To do so, lay a bead of adhesive in the seam and flatten it out with a putty knife pushing it into seam. Use the putty knife to remove any excess adhesive from around the seam area making sure it is flush with the liners